



Roll-A-Shutter™

CRYSTAL-VIEW POLY CARBONATE SHUTTER



The B&D Roll-A-Shutter™ Crystal-View Industrial Type Poly Carbonate Shutter is a contemporary roller shutter, unique in appearance and designed to provide retailers with a door that replicates glass in the shopfront. Ideal for applications such as shopping centre retail spaces, street-facing shop fronts, arcades, sporting complexes, clubs and bars.

The B&D Roll-A-Shutter Crystal-View is manufactured to provide a secure and aesthetically pleasing addition to high-end store fronts or shopping centre retail spaces allowing the continual showcasing of merchandise, even when the shop is closed. The B&D Roll-A-Shutter Crystal-View can be supplied with slotted curtain slats where ventilation is required.

RECOMMENDED APPLICATION

- Ideal for shopping centre retail spaces, street facing shopfronts, arcades and clubs
- Suitable for openings ranging from 1000mm to 3500mm (h) and up to 3000mm (w)
- High level of security.

BOTTOM RAILS

The B&D Roll-A-Shutter Crystal-View is supplied with an aluminium bottom rail. An optional weather seal can be provided upon request, to prevent the entry of foreign particles.

ROLLER DRUM

229mm Spiral drum rotating on a 34mm heavy duty shaft fitted with high speed industrial bearing & helical springs to counterbalance the door in accordance with manufacturers specifications.



Doors & Openers®

THERE'S SO MUCH MORE BEHIND A B&D DOOR

Call 13 62 63 or visit www.bnd.com.au for further information.

THERE'S SO MUCH MORE BEHIND A DOOR

CURTAIN

Poly carbonate door curtain with poly carbonate extrusion.

SIZES

For openings up to 4000mm (h) and 64000mm (w).

PERFORATIONS

Provide 95mm x 25mm vent slots at 70mm spacing where required in the roller shutter.

OPERATION

The B&D Roll-A-Shutter Crystal-View can be either manually operated or motorised depending upon size requirements. There are a range of electric motors available depending on application and usage.

VERSATILE TRACKING SYSTEM

The B&D Roll-A-Shutter Crystal-View is installed with 50mm x 30mm aluminium door tracks which can be mounted between wall fix or behind wall fix. The guides can also accommodate a rubber twin fin extrusion or mohair felt buffer to ensure a quieter operation. Manual doors only are fitted with door stops.

LOCKING

The B&D Roll-A-Shutter Crystal-View may be fitted with a centrally mounted locking mechanism within the bottom rail. Manual door locking mechanisms are not recommended for automatically operated doors.

DIMENSIONS (all measurements in mm)

DOOR HEIGHT	ROLL DIAMETER	CENTRE OF AXLE FROM WALL
900	290	155
1200	290	155
1500	290	155
1800	300	160
2100	300	160
2400	310	165
2700	310	165
3000	320	170
3300	320	170
3600	340	180
4000	340	180

CLEARANCES

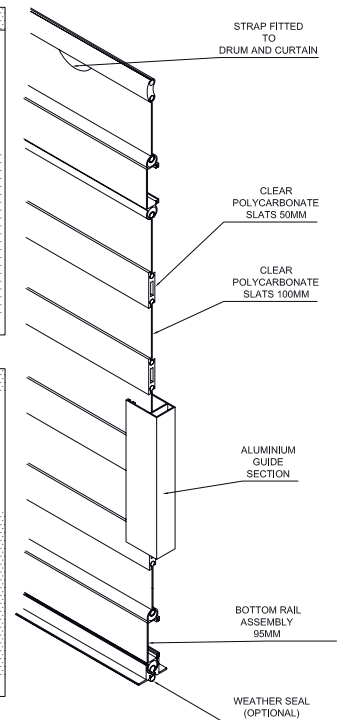
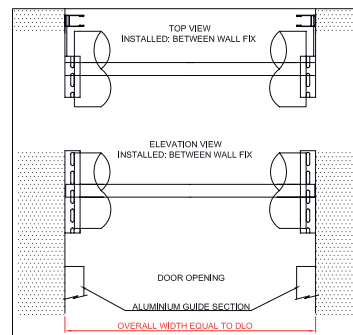
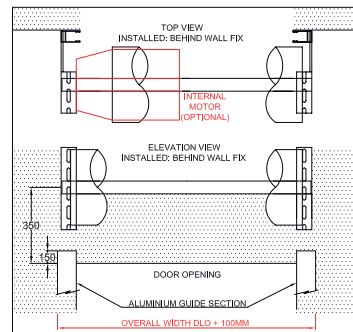
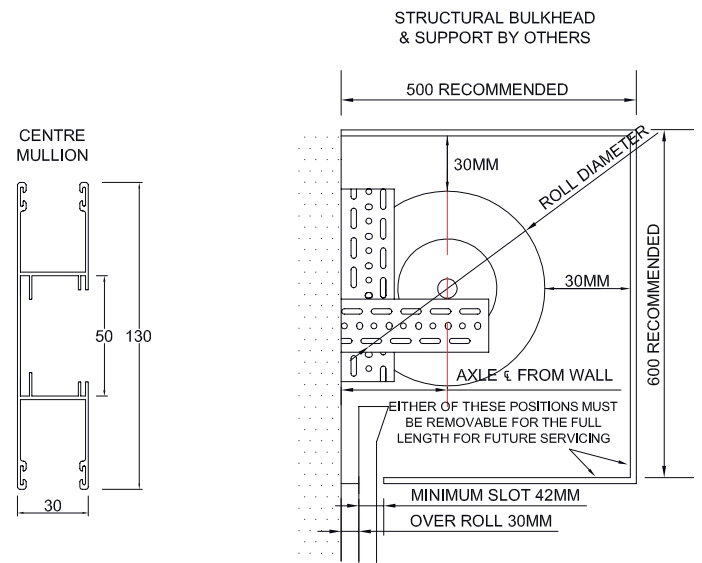

WARRANTY

A 12 month limited material, labour and workmanship warranty applies.

B&D Doors has offices servicing all states. For more details on this product or our other ranges, phone **13 62 63** or visit www.bnd.com.au

Notes / Information

- B&D Roll-A-Shutter™ Crystal-View Industrial Type Poly Carbonate Shutters are covered by a 12 month warranty, for complete door and parts, as recommended in the door's handbook. Full details of the warranty are available from www.bnd.com.au. 12 month warranty only applies to doors purchased and installed in Australia & New Zealand. Warranty only valid if warranty conditions are met.
- For areas within one kilometre of a corrosive environment eg. salt air or industrial fallout, special care and maintenance are generally required. Consult B&D or your B&D Accredited Dealer for advice.
- The company reserves the right to make changes or improvements to the products or accessories without notice and without incurring any obligation to make similar changes or improvements to goods previously ordered. Specifications subject to change without notice.



Doors & Openers®

THERE'S SO MUCH MORE BEHIND A B&D DOOR

Call **13 62 63** or visit www.bnd.com.au for further information.

B&D Doors is a division of B&D Australia Pty Ltd, ABN 25 010 473 971 © 2014 B&D Australia